

E14FID

60cm Fully Integrated Dishwasher

Euromaid



FEATURES	
Finish	Fully Integrated
Place Settings	14
Display	LED Display
Controls	Electronic Buttons
Upper Basket Type	Height Adjustable
Cutlery Tray	Full Width
No. of Spray Arms	3
Adjustable Plate Holders	2
Adjustable Mug Shelves	1
Drying System	Natural
Delay Start	1 - 24 Hours
Flood Protection	Overflow Sensor
Rinse Aid Indicator	Yes
Inner Tub Material	Stainless Steel
Filter Type	3 Stage
Floor Light Indicator	Yes

PROGRAMS	
Program 1	Auto 45 - 55°
Program 2	Intensive 60°
Program 3	Heavy 55°
Program 4	Eco 45°
Program 5	Glass 42°
Program 6	90min 65°
Program 7	Rapid 40°
Program 8	Soak

AUXILIARY FUNCTIONS	
Function 1	Extra Dry
Function 2	Dual Zone Wash
Function 3	Power Wash
Function 4	Express Wash



Scan for more info

E14FID

60cm Fully Integrated Dishwasher

Euromaid

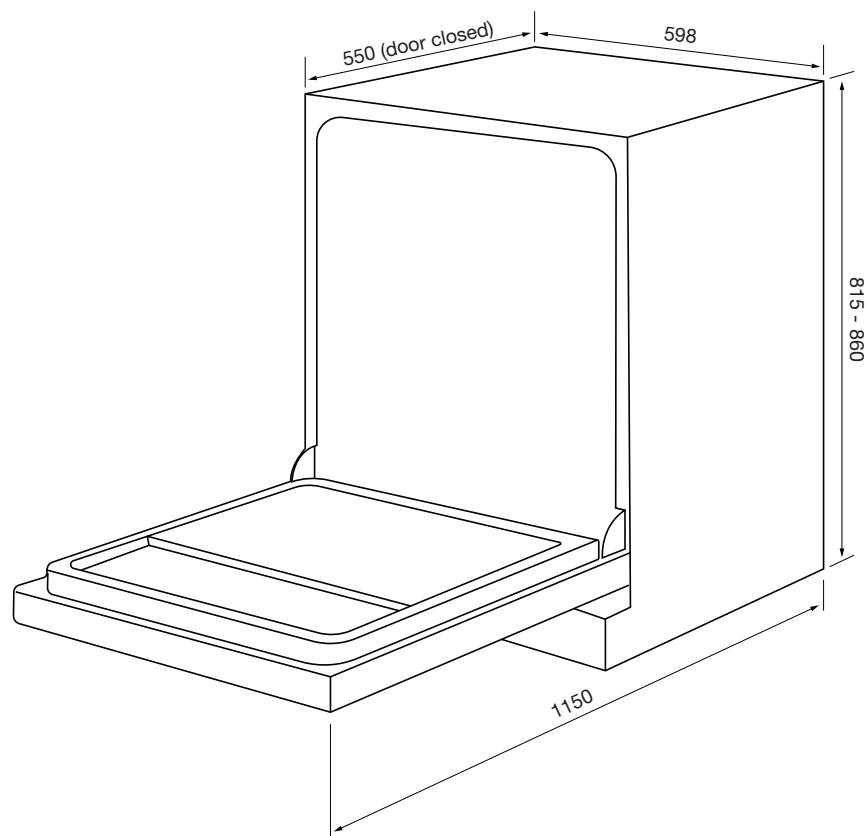

TECHNICAL SPECIFICATIONS

Heating Element	1800W
Motor	Universal
Energy Star Rating	3.5 Stars
Annual Energy Usage (kWh)	259kWh
WELS Star Rating	4.5 Stars
Litres Per Wash Cycle (L)	12L
Noise Level	49dB

INSTALLATION

Electrical Connction	10A Plug & Lead
Power	220 - 240V / 50Hz
Total Power	1760 - 2100W
Installation Type	Fully Integrated

WEIGHTS & DIMENSIONS (W x H x D)

Product (mm)	598 x 815 - 860 x 550
Cut-Out (mm)	600 x 850 - 870 x 600
Carton (mm)	645 x 871 x 645
Gross Weight (kg)	44.0
Net Weight (kg)	39.5

VERSION NO. 20240702